

FACTS | FIGURES | DATA

Pressure retaining valve V 186 · V 86

V 186 V 86



FRANK
PREMIUM-QUALITY PLASTIC

Back pressure valve

Pressure retaining valve V186 · V86

DN 10 to DN 100

Alte portate



V186 PVDF



V186 PP



V186 PVC

USE

Pressure retaining valves V186/V86 are used where a constant back pressure is required for operating process systems. When installed as a bypass, it can also be used as a relief valve for reducing pressure peaks. The Type V186 (DN 10-50) has an almost zero-static lower body that makes it particularly suitable for use in very high-purity water applications. The variety of available materials covers a wide range of applications.

FUNCTION

The set spring force presses the diaphragm onto the seal seat. If the system pressure exceeds the operating pressure value, the valve opens.

SPECIAL FEATURES

- All parts that come into contact with the medium are made of highly-resistant plastics
- The control diaphragm separates the actuating drive from the flow section
- The operating pressure is adjusted with an adjustment screw and is secured with a lock nut. The setting can also be lead sealed if required
- The shape of the housing that assists flow results in good flow values
- Control deviations are kept low by the large control surface and the spiral spring
- No auxiliary energy is required in order to operate the valve
- The valve is largely maintenance-free and can be installed in any position

MATERIALS

Housing	Permissible operating temperature	Diaphragm
PVC-U	0 to +60 °C	EPDM
PP	-10 to +80 °C	EPDM/PTFE coated
PVDF	-20 to +100 °C	

TECHNICAL DATA

Type	Size	PN	Pressure range in bar
V186	DN 10-50	10	0.5 - 10
V86	DN 65-80	6	1 - 6
	DN 100	4	1 - 4

DIMENSIONS IN MM (GUIDELINE VALUES)

d	DN	L	Ls	L1	L2	D	h	H
16	10	134	–	140	154	83	20	137
20	15	134	158	140	154	83	20	137
25	20	134	158	140	154	83	20	137
32	25	174	198	180	185	112	27	199
40	32	174	202	180	248	112	27	199
50	40	224	256	230	248	165	43	290
63	50	244	256	250	252	165	43	290
75	65	284	284	290	280	180	–	275
90	80	360	360	370	–	250	–	410
110	100	380	380	390	–	250	–	485

L = standard connection, Ls = IR butt fusion spigot, standard, for material PP/PVDF, L1 = with flange, L2 = with screw connection

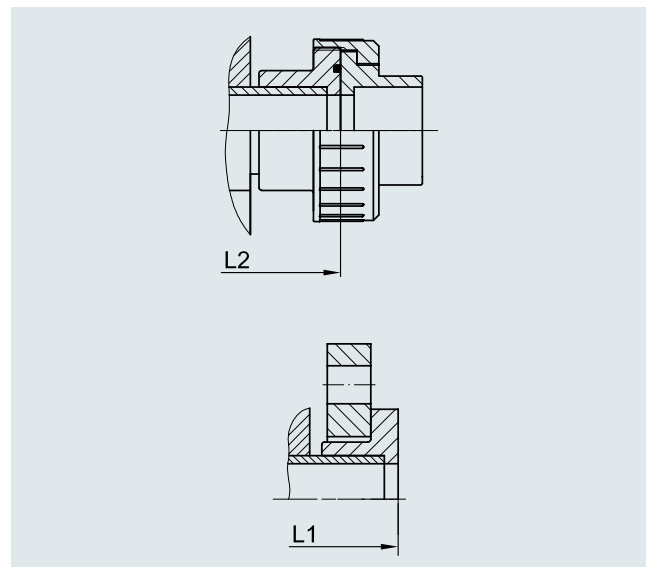
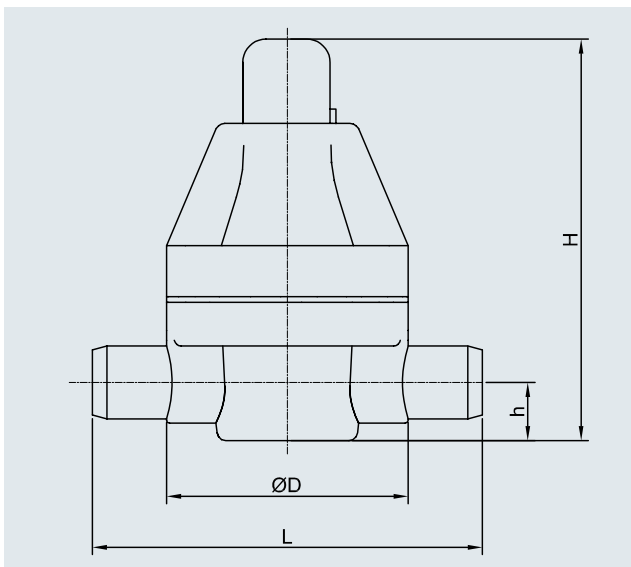

ARTICLE NUMBERS

d	DN	Type	PVC/EPDM	PVC/PTFE	PP/EPDM IR-spigots	PP/PTFE IR-spigots	PVDF/PTFE IR-spigots
16	10	V 186	17.000.134	17.000.149	17.005.472	17.005.479	17.005.486
20	15	V 186	17.000.135	17.000.150	17.005.473	17.005.480	17.005.487
25	20	V 186	17.000.136	17.000.151	17.005.474	17.005.481	17.005.488
32	25	V 186	17.000.137	17.000.152	17.005.475	17.005.482	17.005.489
40	32	V 186	17.000.138	17.000.153	17.005.476	17.005.483	17.005.490
50	40	V 186	17.000.139	17.000.154	17.005.477	17.005.484	17.005.491
63	50	V 186	17.000.140	17.000.155	17.005.478	17.005.485	17.005.492
75	65	V 86	17.003.093	17.003.097	17.005.493	17.005.496	17.005.499
90	80	V 86	17.003.101	17.003.105	17.005.494	17.005.497	–
110	100	V 86	17.003.109	17.003.113	17.005.495	17.005.498	–

INDIVIDUAL PARTS

- Pos. Designation
- 1 Lower body
 - 2 Upper body
 - 3 Diaphragm
 - 4 Compressor
 - 5 Compression spring
 - 6 Spring plate
 - 7 Adjustment screw
 - 8 Cap
 - 9 Set of screws

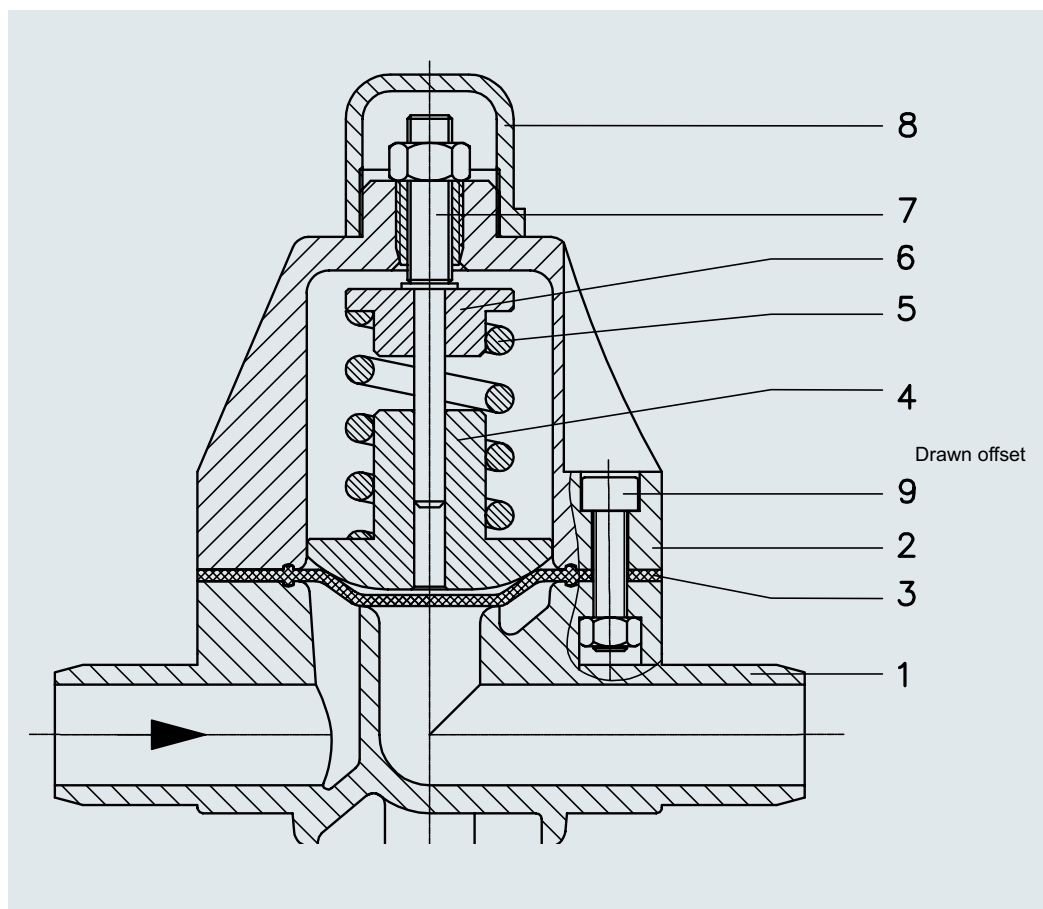

CHARACTERISTIC GRAPHS V 186

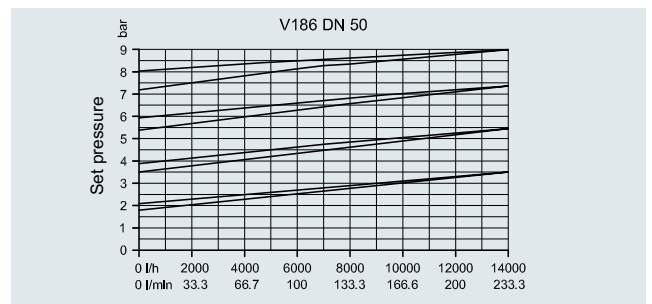
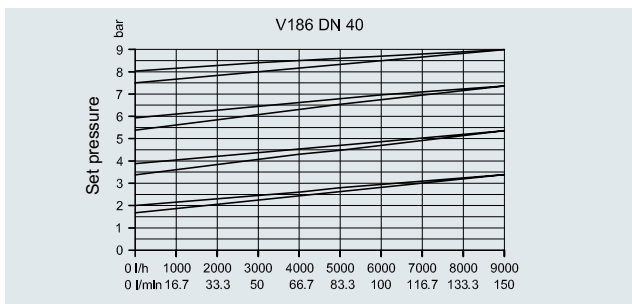
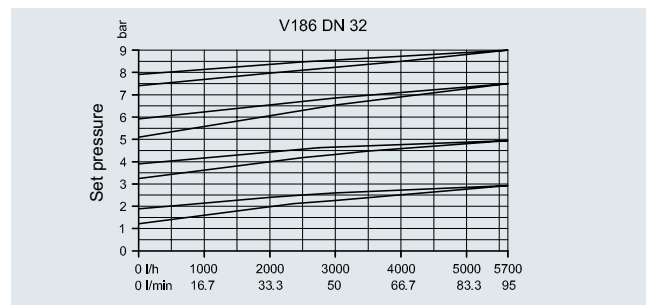
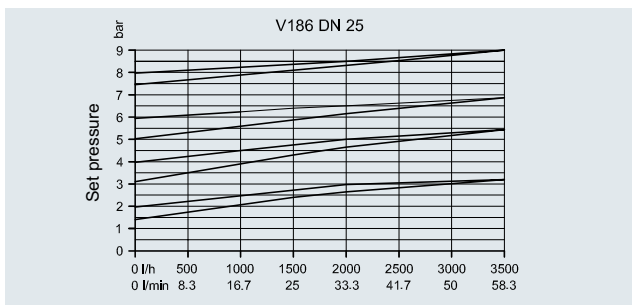
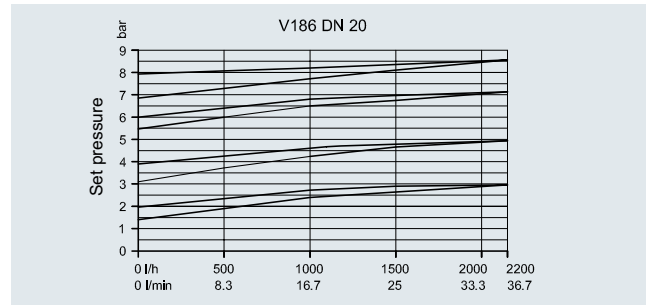
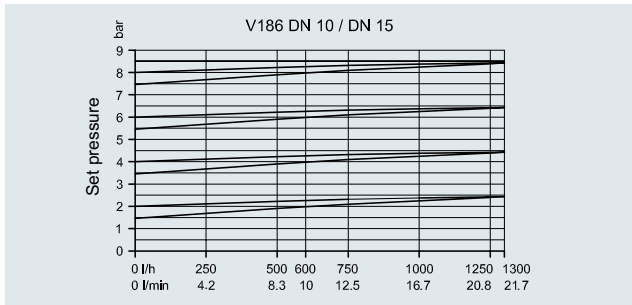

CHARACTERISTIC GRAPHS V 86

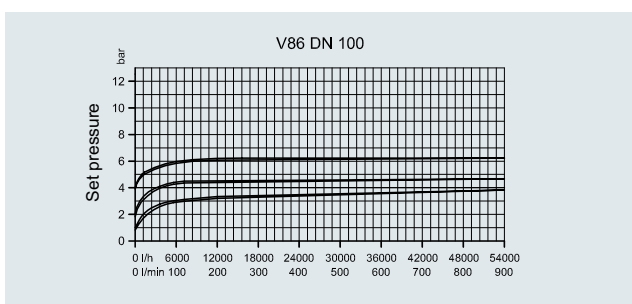
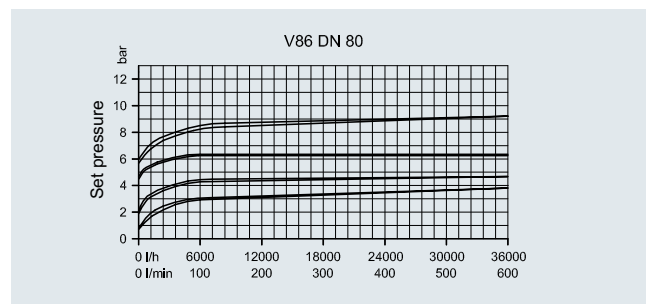
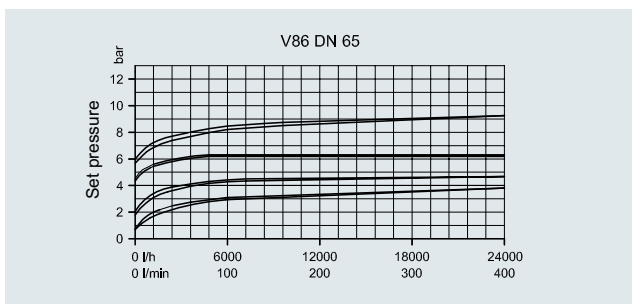

The characteristic curves on the graphs show the increase in the set pressure from 0 through to the maximum permissible flow rate. The upper and lower lines plot the course of the opening and closing pressure respectively. All characteristic curves apply to water at a temperature of 20 °C.

SPARE PARTS SET FOR V 186 / V 86 PVC-U / PP / PVDF

Set consisting of:	Type	DN	PVC/EPDM Article No.	PVC/PTFE Article No.	PP/EPDM Article No.	PP/PTFE Article No.	PVDF/PTFE Article No.
Pos. 3 diaphragm	V 186	10/15/20	17.006.007	17.006.020	17.006.007	17.006.020	17.006.020
Pos. 5 compression ring	V 186	25/32	17.006.008	17.006.021	17.006.008	17.006.021	17.006.021
Pos. 7 adjustment screw	V 186	40/50	17.006.009	17.006.022	17.006.009	17.006.022	17.006.022
Pos. 10 washer							

Set consisting of:	Type	DN	PVC/EPDM Article No.	PVC/PTFE Article No.	PP/EPDM Article No.	PP/PTFE Article No.	PVDF/PTFE Article No.
Pos. 5 diaphragm	V 86	65	17.006.256	17.006.259	17.006.268	17.006.271	17.006.275
Pos. 4 spring assembly	V 86	80	17.006.257	17.006.260	17.006.269	17.006.272	–
Pos. 2 adjustment screw	V 86	100	17.006.258	17.006.261	17.006.270	17.006.273	–
Pos. 10 piston, complete							

V 186

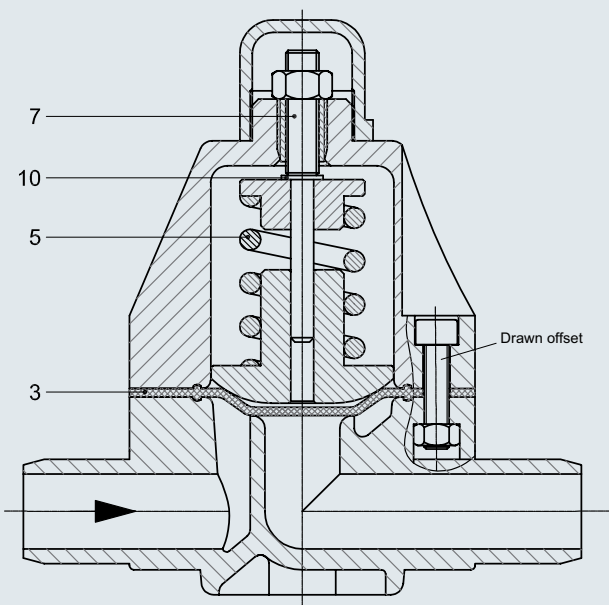

V 86

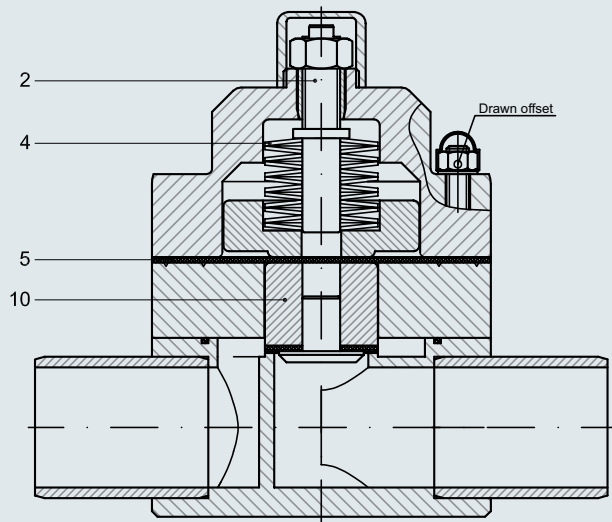

PRESSURE RETAINING VALVE V 186

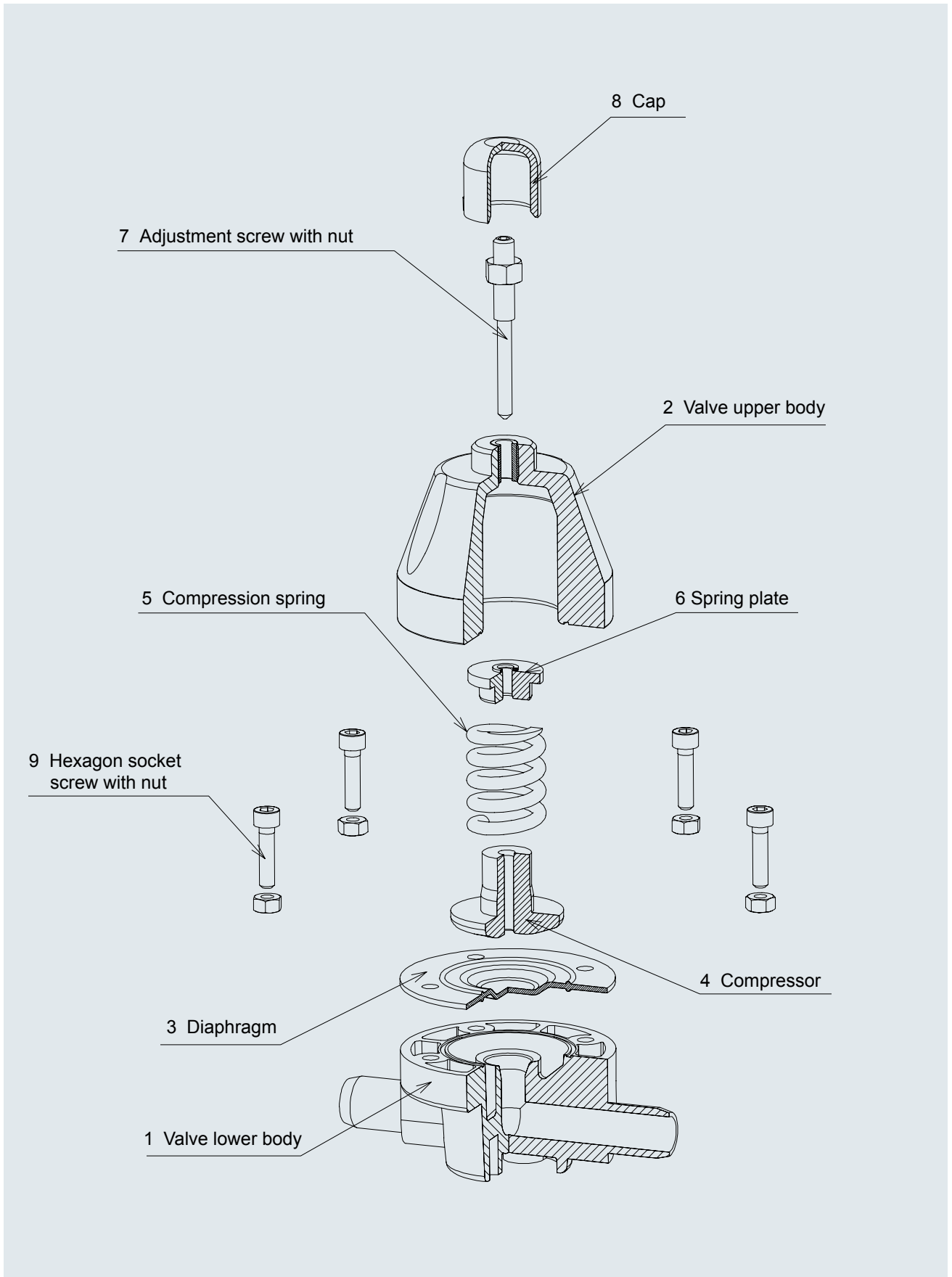

V186.V86



FRANK plastic AG

Herbert-Frank-Straße 26 | 72178 Waldachtal | Germany

Tel. +49 (0) 7486 181 0 | Fax +49 (0) 7486 181 337

info@frankplastic.de | www.frankplastic.de

FRANK

PREMIUM-QUALITY PLASTIC